

OPERATION, INSTALLATION, & MAINTENANCE MANUAL

for

Aircon Flex-air AN Airlocks

Aircon Corporation
P.O. Box 80446
2873 Chelsea Avenue
Memphis, TN 38108-0446
Telephone: (901) 452-0230
FAX: (901) 452-0750

INTRODUCTION

The Aircon "Flex-Air" valve was designed for use as airlocks, pneumatic feeders on conveying systems, or as product metering devices. Available in eight sizes, the valves can maintain an air seal at pressures or vacuums up to 17" WG (water gage). A precision fabricated valve, the "Flex-Air" features a one-piece, full pocket, double wiper design. This design makes it possible to create the best air seal with flexible edge rotors.

Aircon "Flex-Air" Valves are ideal for use in industries such as woodworking, metalworking, grain, paper and many more.

OPERATING PRINCIPLE

A rotary valve (or airlock) offers a means of conveying solid material between two devices of unequal pressures. An airlock may be also be used between either a positive or negative pressured device and the atmosphere. Forming sealed barriers against the inside of the valve body, the six sets of dual wipers are able to resist leakage up to pressure differences of 17" WG. Airlock blades turn at low speeds between 18 and 22 RPM (revolutions per minute), requiring either gear reducers or chains and sprockets for their operation. Forming pockets of displacement between wipers, airlocks are able to meter product in a continuous and consistent manner.

OPERATING INSTRUCTIONS

RECEIVING

Aircon Flex-Air Airlocks are quality manufactured and tested prior to shipment. Upon receipt of order, the customer should check for any possible damage that may have occurred during shipping. The carrier is responsible for any damage incurred in transit. All damage reports must be made with the carrier upon receipt of order.

INSTALLATION

Airlocks will be shipped complete with motor and gear reducer (or chains and sprockets) mounted. If a desired rotation is required, this can be achieved with a short ON/OFF operating cycle and a visual check of shaft rotation. See the rotation arrow on the end plate for proper rotation.

OPERATING REQUIREMENTS

All motors required for Aircon airlocks are three-phase TEFC (Totally Enclosed Fan Cooled) operating at 1800 nominal RPM, requiring a voltage supply of 230 or 460 VAC (volts of alternating current) at 60 hertz.

START-UP CHECKLIST

1. Reducer securely mounted to adaptor plate.
2. Top flange of airlock firmly bolted to flange above it.

ROUTINE MAINTENANCE

Monthly

Lubricate shaft flange bearings.

Quarterly (every three months)

1. Check internal wipers of airlock for signs of wear.
2. Check gear oil level in reducer

SAFETY

Before conducting any maintenance procedures on the airlock, please observe the following safety precautions:

1. Turn off, disconnect, and lock out power to airlock motor and to all fans within the system, and lock out all electrical disconnects for all associated and auxiliary equipment. This includes any level indicator with moving parts in a hopper above the airlock, and especially any type of conveyor located below the airlock.
2. Do not touch the outer surface of the motor housing until the motor has been turned off and allowed to cool for at least twenty minutes.

STANDARD FEATURES OF AIRCON FLEX-AIR AIRLOCKS

1. Flexible-edge rotors of 4-ply Transmission Belting.
2. Lifting lugs to facilitate moving.
3. Chain-driven sprockets complete with hand guard.
4. One coat of rust-inhibitive primer, and one coat of Aircon Machine Gray enamel paint.

OPTIONAL FEATURES OF AIRCON FLEX-AIR AIRLOCKS

1. Explosion proof motors, NEMA 9, class II, groups E, F, & G.
2. Flexible edge rotors of E.P.D.M., polyurethane, silicone, or Teflon.
3. Larger shaft sizes and thicker blades for heavy-duty applications.
4. Paint per customer specifications.

**AN ROUND and SQUARE AIRLOCKS
SUGGESTED SPARE PARTS LIST**

MODEL	QTY.	DESCRIPTION
AN-8	(1)	Std. duty 4-bolt flg. 1 ⁷ / ₁₆ " dia. bearing
	(6)	9 ¹ / ₂ " x 13 ³ / ₄ " x 4-ply trans. belting wipers
	(8)	1 ⁷ / ₁₆ " ID x 2 ¹ / ₄ "OD x ¹ / ₄ " Neoprene spacers
AN-10	(1)	Std. duty 4-bolt flg. 1 ⁷ / ₁₆ " dia. bearing
	(6)	12" x 17" x 4-ply trans. belting wipers
	(8)	1 ⁷ / ₁₆ " ID x 2 ¹ / ₂ "OD x ¹ / ₄ " Neoprene spacers
AN-12	(1)	Std. duty 4-bolt flg. 1 ¹¹ / ₁₆ " dia. bearing
	(6)	13 ¹ / ₂ " x 20 ¹ / ₂ " x 4-ply trans. belting wipers
	(8)	1 ¹¹ / ₁₆ " ID x 2 ¹ / ₂ "OD x ¹ / ₄ " Neoprene spacers
AN-16	(1)	Std. duty 4-bolt flg. 1 ¹⁵ / ₁₆ " dia. bearing
	(6)	17 ¹ / ₂ " x 28 ¹ / ₄ " x 4-ply trans. belting wipers
	(8)	1 ¹⁵ / ₁₆ "ID x 2 ³ / ₄ " OD x ¹ / ₄ " Neoprene spacers
AN-20	(1)	Std. duty 4-bolt flg. 2 ³ / ₁₆ " dia. bearing
	(6)	21 ¹ / ₂ " x 36 ¹ / ₂ " x 4-ply trans. belting wipers
	(8)	2 ³ / ₁₆ " ID x 3 ¹ / ₄ "OD x ¹ / ₄ " Neoprene spacers
AN-24	(1)	Std. duty 4-bolt flg. 2 ³ / ₁₆ " dia. bearing
	(6)	25 ¹ / ₂ " x 42 ¹ / ₂ " x 4-ply trans. belting wipers
	(8)	2 ³ / ₁₆ " ID x 3 ¹ / ₄ "OD x ¹ / ₄ " Neoprene spacers
AN-30	(1)	Std. duty 4-bolt flg. 2 ¹⁵ / ₁₆ " dia. bearing
	(6)	31 ¹ / ₂ " x 54 ¹ / ₂ " x 4-ply trans. belting wipers
	(8)	2 ¹⁵ / ₁₆ " ID x 3 ¹ / ₄ "OD x ¹ / ₄ " Neoprene spacers
NOTES:		All wipers are 4-ply trans belting and spacers 60 durometer neoprene. Six (6) wipers constitute one complete set.

**ANS SQUARE EXTENDED SHAFT AIRLOCK
SUGGESTED SPARE PARTS LIST**

MODEL	QTY.	DESCRIPTION
ANS-8-E	(1)	Std. duty 4-bolt flg. 1 ⁷ / ₁₆ " dia. bearing
	(6)	9 ¹ / ₂ " x 13 ³ / ₄ " x 4-ply trans. belting wipers
	(8)	1 ⁷ / ₁₆ " ID x 2 ¹ / ₄ "OD x ¹ / ₄ " Neoprene spacers
ANS-10-E	(1)	Std. duty 4-bolt flg. 1 ⁷ / ₁₆ " dia. bearing
	(6)	12" x 17" x 4-ply trans. belting wipers
	(8)	1 ⁷ / ₁₆ " ID x 2 ¹ / ₂ "OD x ¹ / ₄ " Neoprene spacers
ANS-12-E	(1)	Std. duty 4-bolt flg. 1 ¹¹ / ₁₆ " dia. bearing
	(6)	13 ¹ / ₂ " x 20 ¹ / ₂ " x 4-ply trans. belting wipers
	(8)	1 ¹¹ / ₁₆ " ID x 2 ¹ / ₂ "OD x ¹ / ₄ " Neoprene spacers
ANS-16-E	(1)	Std. duty 4-bolt flg. 1 ¹⁵ / ₁₆ " dia. bearing
	(6)	17 ¹ / ₂ " x 28 ¹ / ₄ " x 4-ply trans. belting wipers
	(8)	1 ¹⁵ / ₁₆ "ID x 2 ³ / ₄ " OD x ¹ / ₄ " Neoprene spacers

NOTES: All wipers are 4-ply trans belting and spacers 60 durometer neoprene.
Six (6) wipers constitute one complete set.



Aircon Corporation
 P.O. Box 80446 • Memphis, Tennessee 38108
 (901) 452-0230 • FAX (901) 452-0564
 E-mail: sales@aircon-corporation.com
 Website: www.aircon-corporation.com

**Flex-Tip "AN"
 Square Airlocks**

EFFECTIVE:
January 1, 2002
 SUPERSEDES: January 1, 2000

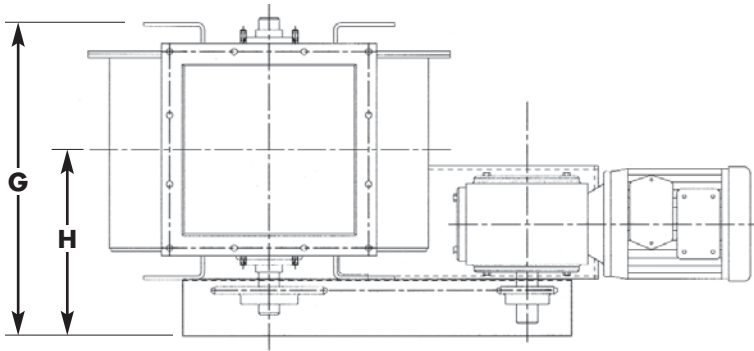

TOP VIEW

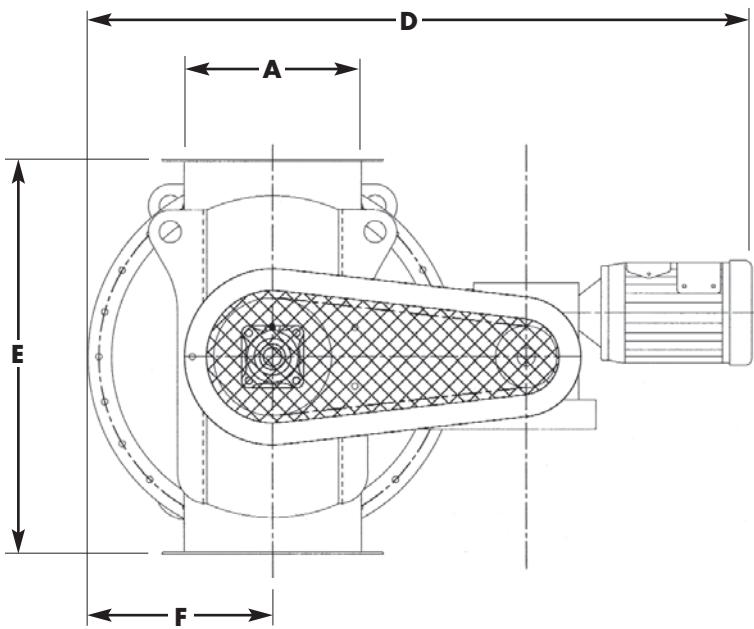
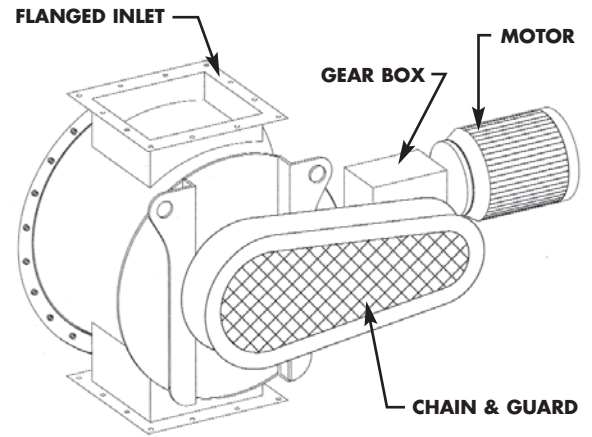

SIDE VIEW

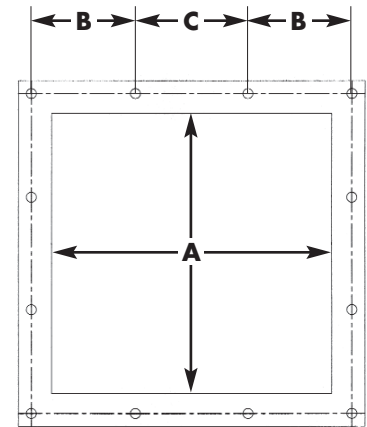

INLET & OUTLET FLANGE

Model #	A	B	C	D	E	F	G	H	Qty. Bolts	Shaft Dia.	Motor (HP)	Capacity (CF/REV)	RPM	Shipping Wt. (lbs.)
ANS-8	8 1/8"	4 15/16"	* 0"	36 1/4"	20 1/8"	9 1/8"	17 1/4"	10 3/8"	8	1 7/16"	1/2	0.64	21.1	244
ANS-10	10 1/8"	4"	4"	40 1/2"	23 1/8"	10 5/8"	20"	11 7/8"	12	1 7/16"	3/4	1.34	19.9	320
ANS-12	12 1/8"	4 1/2"	4 7/8"	45 1/2"	27"	12 5/8"	22 1/2"	13 1/4"	12	1 11/16"	1	2.46	18.6	430
ANS-16	16 1/8"	6"	5 3/4"	55 3/4"	35"	16 1/2"	26 1/2"	15 3/8"	12	1 15/16"	2	6.20	17.4	690

NOTE: All bolt holes are 7/16" diameter • * AN-8 Has only 8 holes equally spaced



Aircon Corporation

P.O. Box 80446 • Memphis, Tennessee 38108
 (901) 452-0230 • FAX (901) 452-0564
 E-mail: sales@aircon-corporation.com
 Website: www.aircon-corporation.com

**Flex-Tip "AN"
 Round Airlocks**

EFFECTIVE:
January 1, 2002
 SUPERSEDES: January 1, 2000

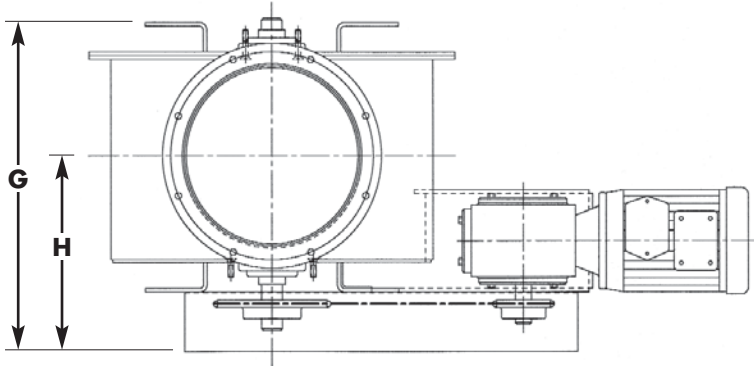

TOP VIEW

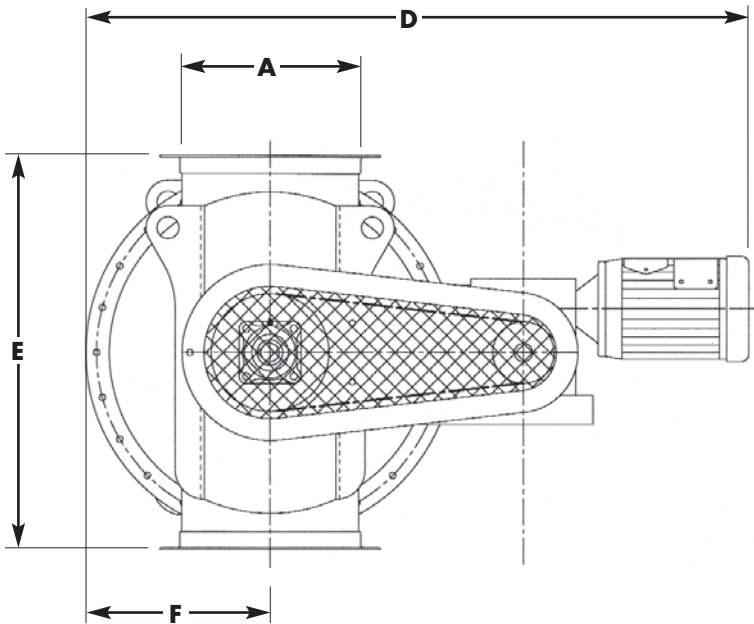
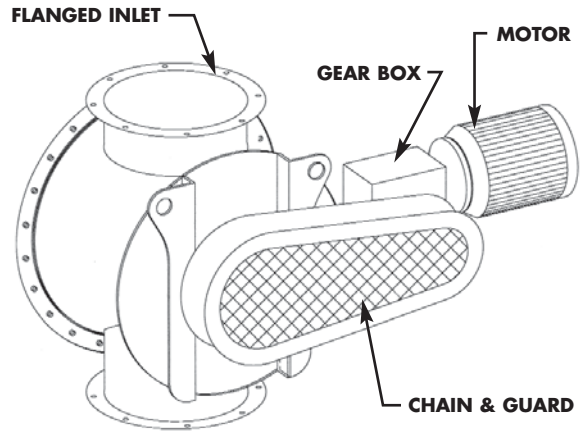

SIDE VIEW

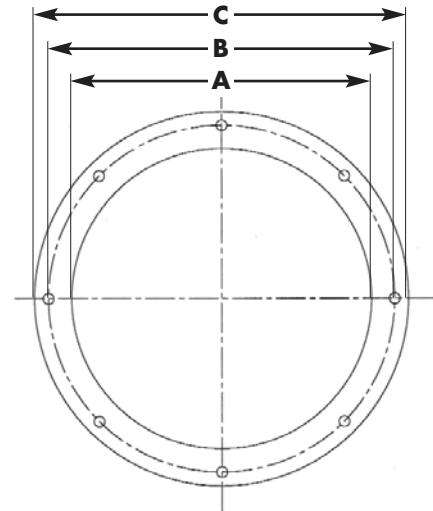

INLET & OUTLET FLANGE

Model #	A	B	C	D	E	F	G	H	Qty. Bolts	Shaft Dia.	Motor (HP)	Capacity (CF/REV)	RPM	Shipping Wt. (lbs.)
AN-8	8 1/8"	9 9/16"	10 3/8"	36 1/4"	20 1/8"	9 1/8"	17 1/4"	10 3/8"	6	1 7/16"	1/2	0.64	21.1	244
AN-10	10 1/8"	11 13/16"	12 7/8"	40 1/2"	23 1/8"	10 5/8"	20"	11 7/8"	6	1 7/16"	3/4	1.34	19.9	320
AN-12	12 1/8"	14"	15 1/8"	45 1/2"	27"	12 5/8"	22 1/2"	13 1/4"	8	1 11/16"	1	2.46	18.6	430
AN-16	16 1/8"	18"	19 1/8"	55 3/4"	35"	16 1/2"	26 1/2"	15 3/8"	8	1 15/16"	2	6.20	17.4	690
AN-20	20 1/8"	21 3/4"	23 1/8"	68 1/4"	43 1/2"	20 3/4"	31 3/8"	17 7/8"	12	2 3/16"	3	12.6	17.4	1070
AN-24	24 1/8"	25 7/8"	27 1/8"	74 3/8"	49 1/2"	23 3/4"	35 3/8"	19 7/8"	12	2 3/16"	3	21.0	17.4	1215
AN-30	30 1/8"	32 3/8"	34 1/8"	86 1/4"	63 1/2"	29 3/4"	44 3/8"	24 7/8"	16	2 15/16"	5	43.0	15.5	2155

NOTE: All bolt holes are 7/16" diameter, except AN-8 (3/8" diameter)